

PRECISION[®]

Back stops
Type RSCI
with disengaging
sprags



In Technical collaboration with STIEBER GmbH, Germany

- Centrifugal lift-off sprags.
- Low lift-off speeds.
- Maintenance free
- High reliability
- Compact design
- Easy mounting & dismantling
- Simple change of direction of rotation
- Requires minimum lubrication
- Does not increase working temperature of the system

APPLICATIONS:

Can be used as a backstop

- In gear drives for conveyors, bucket elevators, turbines, generators, ovens, compressors.
- On electric motors
- On pumps
- On industrial fans

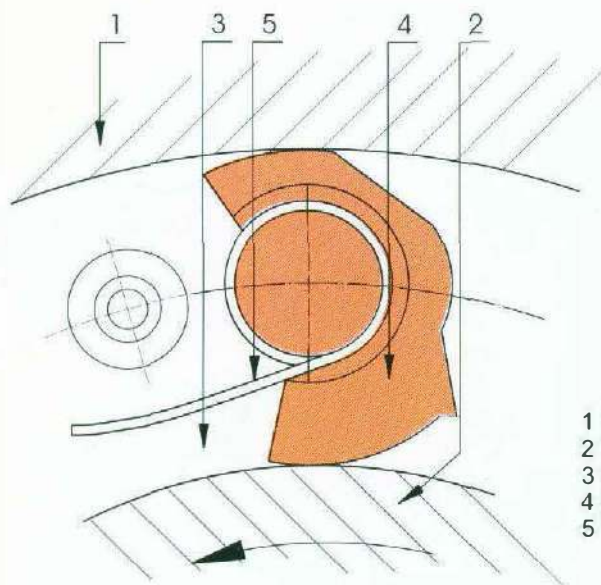
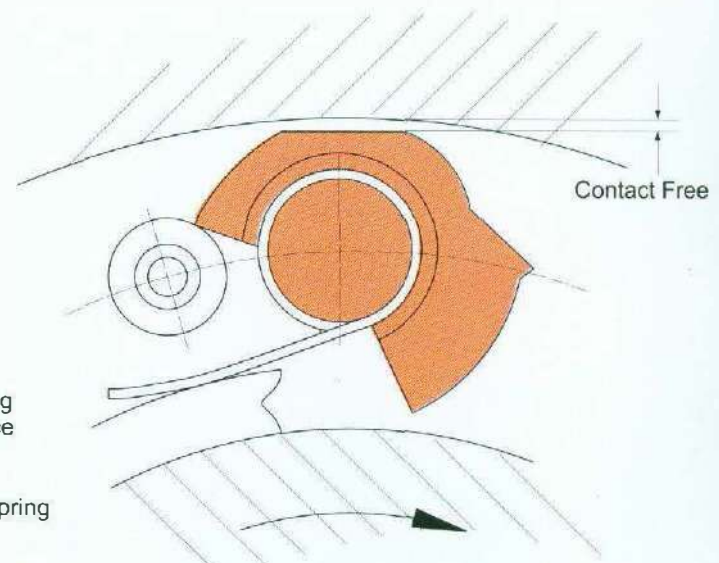
**Transmitting Torque****Overrunning****DESCRIPTION:**

The RSCI type is mainly used as a backstop. The inner ring (2) rotates together with sprag cage (3) in freewheeling direction. Each sprag (4) is individually spring loaded (5) & precisely guided in the cage. The outer race is firmly secured to the stationary part of the machine. The cage is connected to the rotating inner race by means of drive pins & circlips.

When disengaging speed is reached the sprags automatically disengage completely from the contact surface of the outer race & rotate contact free without any wear. RSCI backstop do not have bearings of their own & these must be built in by the designer.

To ensure faultless operation, inner & outer races have to be aligned exactly according to the permissible squareness & concentricity tolerances. (See example)

Recommended shaft tolerance is h6 or j6 & centering spigot tolerance h6 or j6.

LUBRICATION:

Above disengaging speed the backstop need only be protected against corrosion. In case of frequent starts and stops or long slowing down periods oil lubrication should be provided. As a result of designed sprag characteristics the oils with HP or EP additives can be used. In such cases the permissible squareness and concentricity tolerance must be halved.

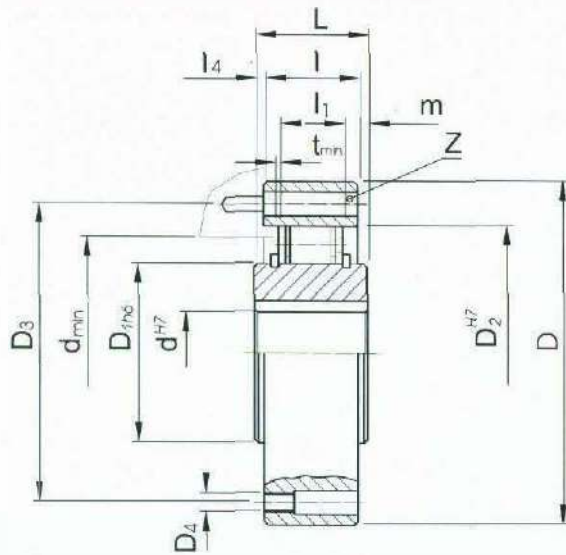

RSCI Backstop

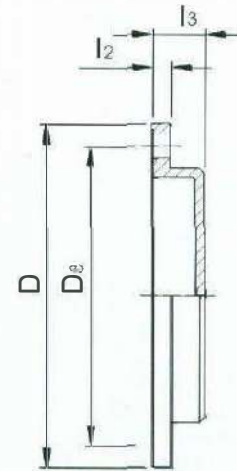

F8 Cover

Type dH7	Torque		Speeds			D	D ₁ h6	D ₂	D ₃	D ₄	Z	L	l	l ₁	l ₄	d _{min}	m	t _{min}	l ₂	l ₃	Weight	
	T _{kn} Nm	n _{max} 2)	n _{i_min} 3)	n _{i_max} 4)	RSCI																F8	
RSCI-20	212	380	875	14500	90	36	66	78	M6	6	35	35	25	0	52	5	1	8	16	1.5	0.3	
RSCI-25	319	355	825	14300	95	40	70	82	M6	6	35	35	25	0	56	5	1	8	16	1.6	0.4	
RSCI-30	375	350	780	11400	100	45	75	87	M6	6	35	35	25	0	62	5	1	8	16	1.8	0.4	
RSCI-35	550	320	740	10500	110	50	80	96	M6	8	35	35	25	0	66	5	1	8	16	2.1	0.5	
RSCI-40	800	315	720	7600	125	60	90	108	M8	8	35	35	25	0	76	5	1	10	21	2.7	0.7	
RSCI-45	912	285	665	6600	130	65	95	112	M8	8	35	35	25	0	82	5	1	10	21	2.9	0.9	
RSCI-50	1400	265	610	6100	150	80	110	132	M8	8	40	40	25	0	100	7.5	1	10	21	4.3	1.0	
RSCI-60	2350	200	490	6100	175	85	125	155	M10	8	60	50	36	5	110	12	2	12	35	6.5	1.8	
RSCI-70	3050	210	480	4500	190	100	140	165	M10	12	60	50	36	5	120	12	2	12	35	8.6	1.9	
RSCI-80	4500	190	450	4000	210	120	160	185	M10	12	70	60	36	5	140	17	3	12	35	12.5	2.6	
RSCI-90	5600	180	420	3000	230	140	180	206	M12	12	80	70	36	5	160	22	3	12	35	17.4	3.0	
RSCI-100	10500	200	455	2700	290	140	210	258	M16	12	90	80	52.6	5	180	18.6	3	15	37	28	5.0	
RSCI-130	15750	180	415	2400	322	170	240	278	M16	12	90	80	52.6	5	210	18.6	3	15	37	35	6.0	
RSCI-180	31500	160	365	1300	412	240	310	360	M20	12	90	80	52.6	5	280	18.6	3	18	44	61	15	
RSCI-180-II	63000	160	365	1300	412	240	310	360	M20	24	160	160	118	0	280	21	3	18	44	118	15	
RSCI-220	46250	140	325	1100	470	290	360	410	M20	16	105	80	58.6	5	330	19.5	3	18	67	88	21	
RSCI-220-II	96000	140	325	1100	480	290	360	410	M24	24	160	160	130	0	330	15	3	18	67	167	21	

NOTES:

- 1) T_{max} = 2 x T_{kn}
- 2) This maximum allowable torque transmission speed 'n_{max}' must not be exceeded when transmitting torque.
- 3) This minimum allowable overrunning speed 'n_{i_min}' should not be reduced under continuous operation.
Possible reduction of this minimum speed on request.
- 4) Max Inner race overrunning speed.
- 5) Cover F8 must be ordered separately.
- 6) Keyway to DIN 6885.1.
- 7) All dimensions are in mm.

MOUNTING EXAMPLE

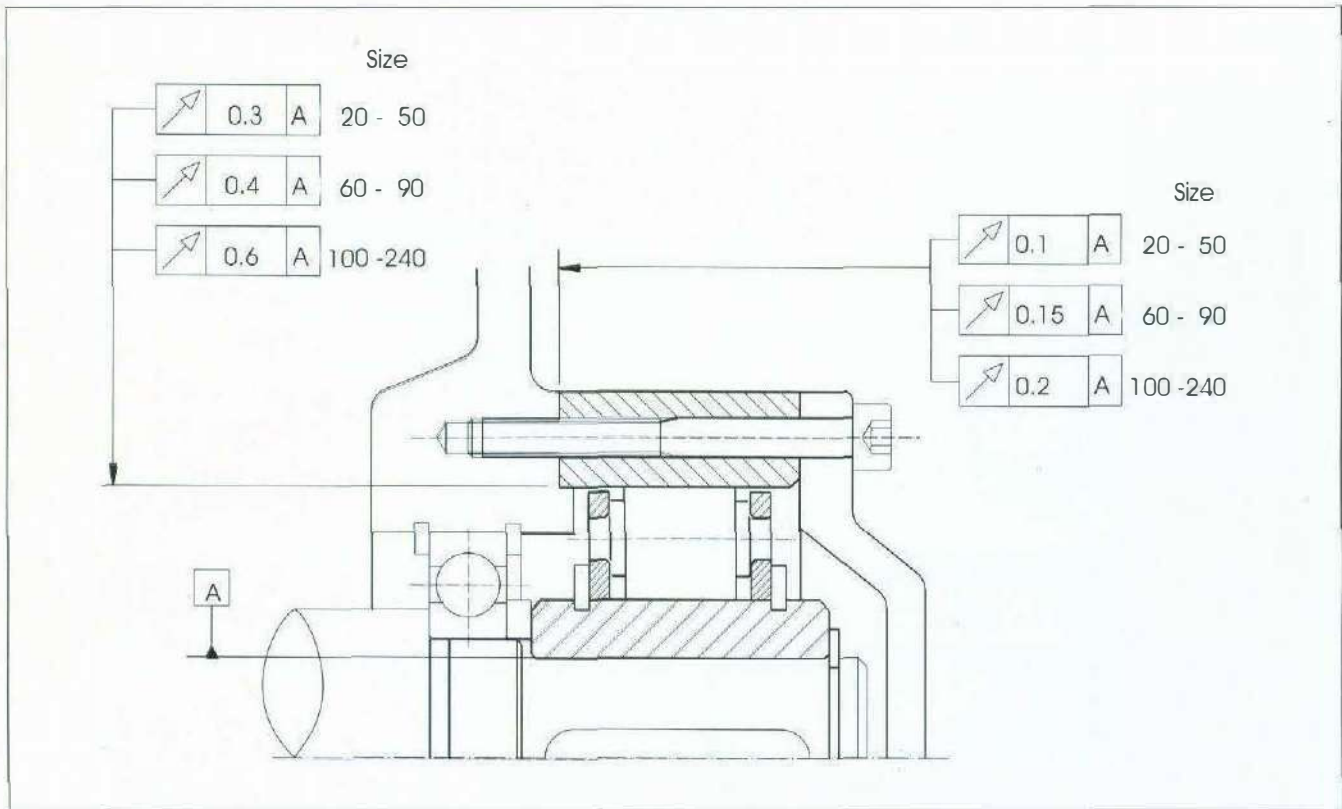

MOUNTING AND MAINTENANCE:

Prior to mounting shaft and mounting flange with spigot have to be cleaned thoroughly. Check if the freewheeling direction is correct. The outer race should be located on its inner diameter only. Bearings must be provided to ensure concentricity of the inner and outer races and support axial and radial loads. Concentricity and runout must be maintained within a limits as shown above. The outer race is fixed to the housing by means of bolts of minimum grade of 8.8

To prevent damage make sure that the drive is not started in backstopping direction. Prior to putting into operating check if the backstop can be easily rotated in the specified over running direction.

If grease is used as a lubricant then over-greasing of the backstop has to be avoided. In case of oil, change the oil initially after 100 operating hours and then every 2000 operating hours. If operational environment is very dirty a more frequent change of oil may be required.

Reversal of overrunning direction is achieved by turning over the cage. Make sure that the cage is not under load while removing. Removal of cage under load is not possible.

PRECISION TRANSMATIC DEVICES PVT. LTD.

B-48, M.I.D.C., Satara - 415 004. (India)

Tel.: +91 (2162) 244454, 246245, 245254, 245354

Fax.: +91 (2162) 244204.

Email: sales@ptdin.com